



VESTIL MANUFACTURING CORP.

2999 North Wayne Street, P.O. Box 507, Angola, IN 46703
 Telephone: (260) 665-7586 -or- Toll Free (800) 348-0868
 Fax: (260) 665-1339

www.vestilmfg.com e-mail: info@vestil.com

FORK-MOUNTED DRUM HANDLERS

DCR-205-8; DCR-205-8-DC; DCR-205-12-DC; DCR-205-15; DCR-205-20

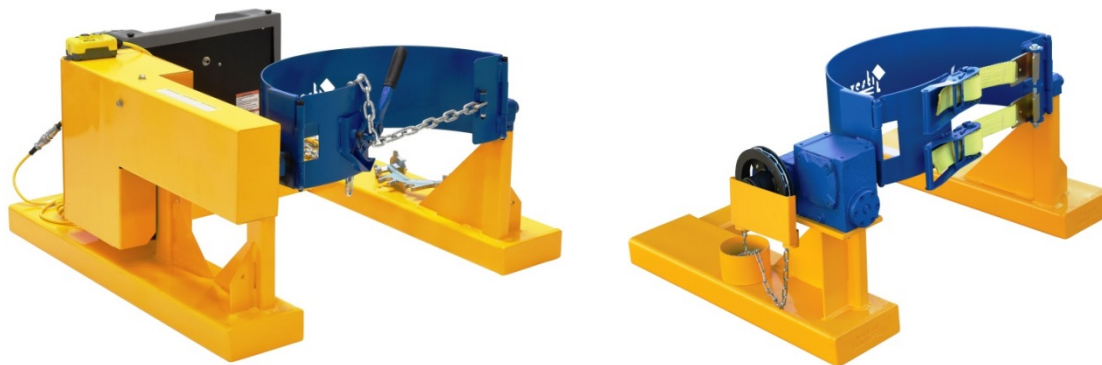

Receiving Instructions

After delivery, remove the packaging from the product. Inspect the product closely to determine whether it sustained damage during transport. If damage is discovered, record a complete description of it on the bill of lading. If the product is undamaged, discard the packaging.

NOTE: The end-user is solely responsible for confirming that product design, use, and maintenance comply with laws, regulations, codes, and mandatory standards applied where the product is used.

Technical Service & Replacement Parts

For answers to questions not addressed in these instructions and to order replacement parts, labels, and accessories, call our Technical Service and Parts Department at (260) 665-7586. The department can also be contacted online at <https://www.vestil.com/page-parts-request.php>.

Electronic copies of Instruction Manuals

Additional copies of this instruction manual may be downloaded from <https://www.vestil.com/page-manuals.php>.

Table of Contents	Page
Signal Words.....	2
Safety Instructions.....	2
Specifications.....	3
National Standards.....	3
FIG. 1: DCR-205-08-DC Exploded View & Bill of Materials.....	4
FIG. 2: DCR-205-08 Exploded View & Bill of Materials.....	5
FIG. 3: DCR-205-12-DC Exploded View & Bill of Materials.....	6
FIG. 4: DCR-205-15 Exploded View & Bill of Materials.....	7
FIG. 5: DCR-205-20 Exploded View & Bill of Materials.....	8
Using the Carrier: Manual Models.....	9
Using the Carrier: Powered Models.....	10
Record of Satisfactory Condition.....	10
Inspections and Maintenance.....	11 - 12
Labeling Diagram.....	12
Limited Warranty.....	13

SIGNAL WORDS

This manual uses SIGNAL WORDS to indicate the likelihood of personal injuries, as well as the probable seriousness of those injuries, if the product is misused in the ways described. Other signal words call attention to uses of the product likely cause property damage. The following are signal words used in this manual and their definitions.

⚠ DANGER

Identifies a hazardous situation which, if not avoided, **WILL** result in **DEATH** or **SERIOUS INJURY**. Use of this signal word is limited to the most extreme situations.

⚠ WARNING

Identifies a hazardous situation which, if not avoided, **COULD** result in **DEATH** or **SERIOUS INJURY**.

⚠ CAUTION

Indicates a hazardous situation which, if not avoided, **COULD** result in **MINOR** or **MODERATE** injury.

NOTICE

Identifies practices likely to result in product/property damage, such as operation that might damage the product.

SAFETY INSTRUCTIONS

Vestil strives to identify all hazards associated with the use of our products. However, material handling is dangerous and no manual can address every risk. The most effective way to avoid injury is for the end-user to exercise sound judgment whenever using this product.

⚠ WARNING

If this product is used improperly or carelessly, the operator and/or bystanders might sustain serious personal injuries or even be killed. ALWAYS use the product properly:

- Failure to read and understand the entire manual before assembling, installing, using or servicing the product is a misuse of the product. Read the manual to refresh your understanding of proper use and maintenance procedures.
- DO NOT exceed the maximum rated load. See Label 1153 on product; also shown in [LABELING DIAGRAM](#) on p. 12.
- Mark your forklift truck to identify the drum carrier attachment and show the approximate weight of the truck and attachment combination at maximum elevation with load laterally centered. Capacity, operation, and maintenance instruction plates, tags, or decals must be changed accordingly.
- DO NOT use the DCR until you read and understand the entire manual. Review the manual as frequently as necessary to refresh your understanding of recommended use or maintenance procedures. Maintenance personnel should also read the manual before maintaining or servicing the drum carrier.
- DO NOT use the carrier unless you are trained to use it.
- Inspect the drum carrier as instructed in the [INSPECTIONS & MAINTENANCE](#) on p. 11-12. DO NOT use the device unless it is in satisfactory condition. If you observe any structural damage (for example, significant damage to either or both fork pockets, the safety chain, or the drum-gripping mechanism), tag the unit "Out of Service" and report the damage to maintenance personnel. DO NOT use the carrier until it is restored to normal condition.
- DO NOT allow people to ride or play on the drum carrier.
- ONLY use the DCR to lift and transport drums. ALWAYS confirm that the drum is securely gripped before driving the drum to a new location.
- DO NOT leave an elevated drum unattended. Lower the drum to the ground; then disconnect the drum cradle. Back the forklift away from the drum until the drum and drum carrier are completely free of each other.
- DO NOT use the DCR if the drum cradle assembly or the cradle closure is damaged or broken. ONLY use the carrier if the cradle and closure function properly.
- DO NOT attempt to resolve any problems with this product unless you are certain that it will be safe to use afterwards.
- DO NOT modify the carrier in any way. **Unauthorized modifications automatically void the [LIMITED WARRANTY](#) (see p. 13) and might make the product unsafe to use.**

SPECIFICATIONS

Documents that provide specifications for DCR-205 series fork-mounted drum carriers are available online to anyone who visits Vestil's website. Specifications include dimensions, centers of gravity, net weight, and capacity information. To access the appropriate specifications document, navigate to this webpage: <https://www.vestil.com/product.php?FID=770>. Click the *Product Specifications Table* tab. Scroll the page to the entry for the model you purchased, and click the button in the *PDF* column that looks like a pencil inside a box. A PDF file will open. This file is the specifications document for your dock leveler. Print a copy of the document and keep it with your copy of this manual. The following is an exemplar specifications document for model DCR-205-8-DC.

FORK TRUCK DRUM CARRIER/ROTATOR - DCR-205-12-DC APPROX WEIGHT: 270.07 lbs. DOES NOT INCLUDE WEIGHT OF POWER OR PACKAGING!!!

*** ANY ADDITIONS, DELETIONS, OR OMISSIONS MUST BE CORRECTED ON THIS DRAWING AS THIS DRAWING WILL BE CONSIDERED ALL INCLUSIVE ***

ALL GRAPHICS PROVIDED ARE FOR REFERENCE ONLY. IF CERTAIN DIMENSIONS ARE CRITICAL PLEASE VERIFY THOSE DIMENSIONS WITH YOUR SALESPERSON

STANDARD FEATURES

- MODEL NUMBER IS DCR-205-12-DC
- OVERALL WIDTH IS 40"
- OVERALL LENGTH IS 46"
- OVERALL HEIGHT IS 24 5/16"
- FITS 1- 55 GALLON DRUM
- MAX CAPACITY IS 1,200 LBS.
- FORK TRUCK RESTRAINT CHAIN LENGTH IS 56"
- FORK POCKET CENTER-TO-CENTER IS 32"
- USABLE FORK POCKET SIZE IS 7 5/8"X2 5/8"
- BUNG WRENCH INCLUDED (NOT SHOWN)
- LOST LOAD IS 275 LBS. (APPROX)
- EFFECTIVE THICKNESS IS FORK LENGTH MINUS 38 1/2"
- DC POWERED HAND HELD CONTROL
- ON BOARD BATTERY CHARGER AND INDICATOR GAUGE
- FRAME IS TOUGH BAKED IN POWDER COATED YELLOW FINISH
- CRADLE IS TOUGH BAKED IN POWDER COATED BLUE FINISH

SPECIAL FEATURES

NONE

NEVER EXCEED LOAD CENTER RATING PER FORK TRUCK MANUFACTURER'S GUIDELINES. DO NOT USE THIS FORK TRUCK ATTACHMENT IF LOAD WILL EXCEED FORK TRUCK MANUFACTURER'S LOAD CENTER RATING.

APPROVAL

I, THE UNDERSIGNED, AGREE THAT THE PRODUCT AS REPRESENTED SATISFIES DESIGN AND DIMENSION REQUIREMENTS. I ALSO ACKNOWLEDGE MY DUTY TO CONFIRM PRODUCT AND INSTALLATION COMPLIANCE WITH ALL APPLICABLE FEDERAL, STATE AND LOCAL REGULATIONS AND STANDARDS.

UNITS REQUIRING APPROVAL DRAWINGS OR MODIFIED ARE NON-RETURNABLE

[] As drawn [] As marked

Signed: _____ Date: _____

Printed Name: _____

LEAD TIME WILL START UPON RECEIPT OF SIGNED APPROVAL DRAWING

FOR INTERNAL USE ONLY PROJECT SIGN OFF	DISTRIBUTOR'S NAME: VESTIL MANUFACTURING		P.O.# X
SALES			W.O.# X
ENG.	DRAWN BY: CRA	DATE: 9/30/2013	SALES: X
FAB.	REFERENCE: X	SCALE: 1:18	FILE NAME:
POWER	QUOTED LEAD TIME: X	QUOTE # X	09-007-112

NATIONAL STANDARDS

US OSHA Rule 1910.178 (29 CFR 1910.178; the "Rule") classifies this device as a front end attachment whenever it is mounted on a lift truck. The Rule incorporates American National Standard ANSI/ITSDF B56.1 (the "Standard"). The Standard is published by the Industrial Truck Standards Development Foundation on its website (www.itsdf.org) where it is freely downloadable at <http://www.itsdf.org/cue/b56-standards.html>. Before putting this device into service, acquire a copy of the Standard. Apply all relevant parts of Part II: For the User. If instructions provided in this manual conflict with the Standard, then you should apply the instructions in the Standard. Vestil requests that you immediately report conflicts to its [TECHNICAL SERVICE](#) department. Contact information for the [TECHNICAL SERVICE](#) department appears on the cover page of this manual.

FIG. 1: DCR-205-8-DC EXPLODED VIEW AND BILL OF MATERIALS (09-006-112-001)

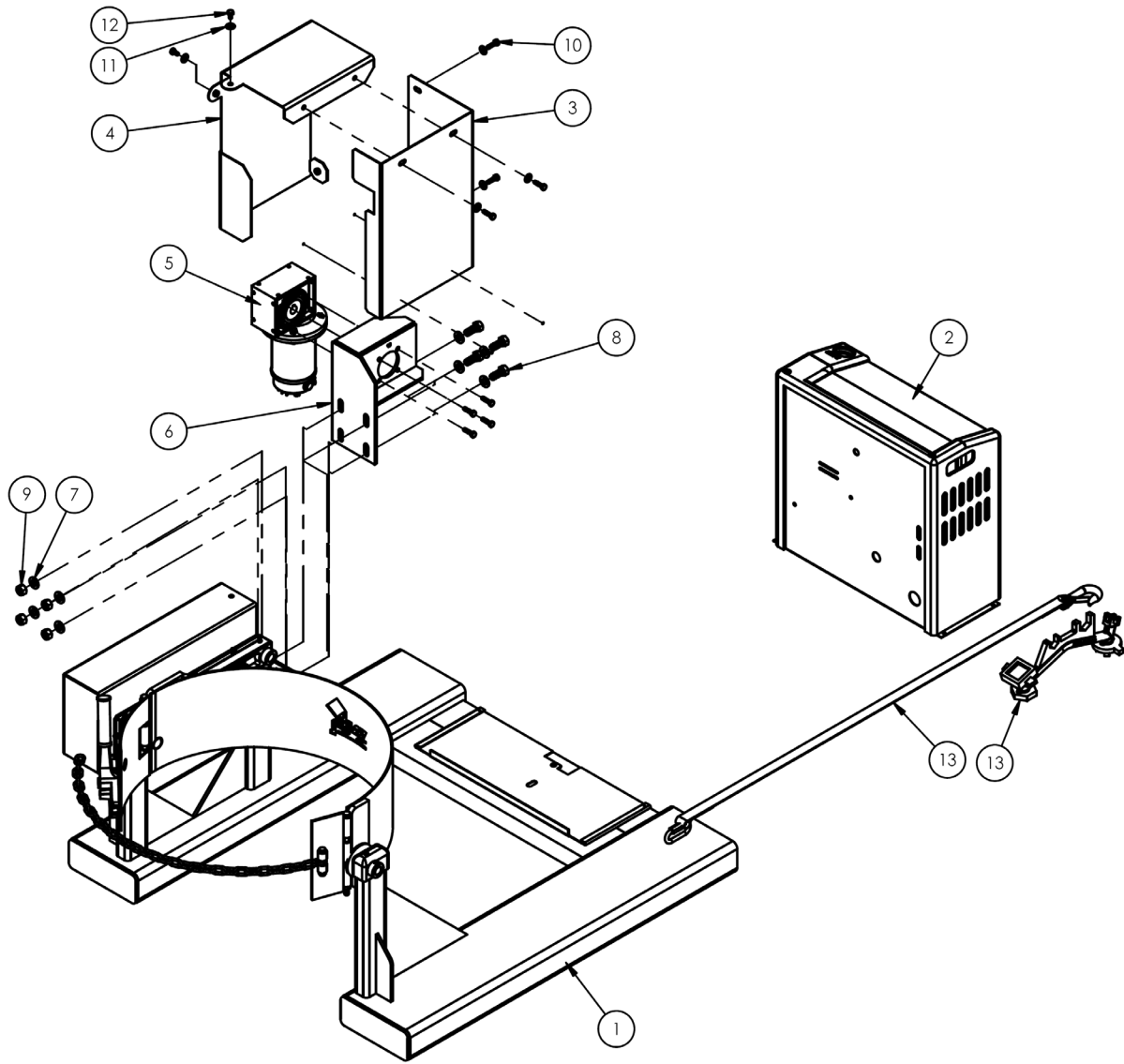

Item	Part No.	Description	Qty.	Item	Part No.	Description	Qty.
1	09-514-164	WELDMENT, FRAME W/SADDLE	1	8	11207	HHCS #2 Z Plated, GRADE A, Ø1/2 - 13 x 1 1/4 LG	4
2	99-160-097	FINAL ASS'Y, MOD. POWER UNIT-DC (XXE)	1	9	36110	HEX NUT Z-PLATED, GRADE A, Ø 1/2 - 13	4
3	09-024-018	GUARD,MOTOR SHROUD,FORMED	1	10	11005	BOLT, GRADE A, Ø1/4-20 UNC x 1 LG, HHCS #2 Z-PLATED	8
4	09-524-003	WELDMENT, GUARD, MOTOR SHROUD	1	11	33004	FLAT WASHER, USS, ZINC PLATED, Ø1/4"	6
5	21-641-005	MOTOR, WITH GEARBOX, SHAFT & KEY STOCK	1	12	11001	HEX BOLT, GRADE A, ZINC PLATED, 1/4"-20 X 1 1/2"	2
6	09-516-080	BRACKET, WELDMENT, MOTOR MOUNT	1	13	09-154-023	CARRIAGE STRAP AND BUNG WRENCH KIT	1
7	33011	FLAT WASHER, USS, PLAIN FINISH, Ø1/2"	8				

FIG. 2: DCR-205-8 EXPLODED VIEW AND BILL OF MATERIALS

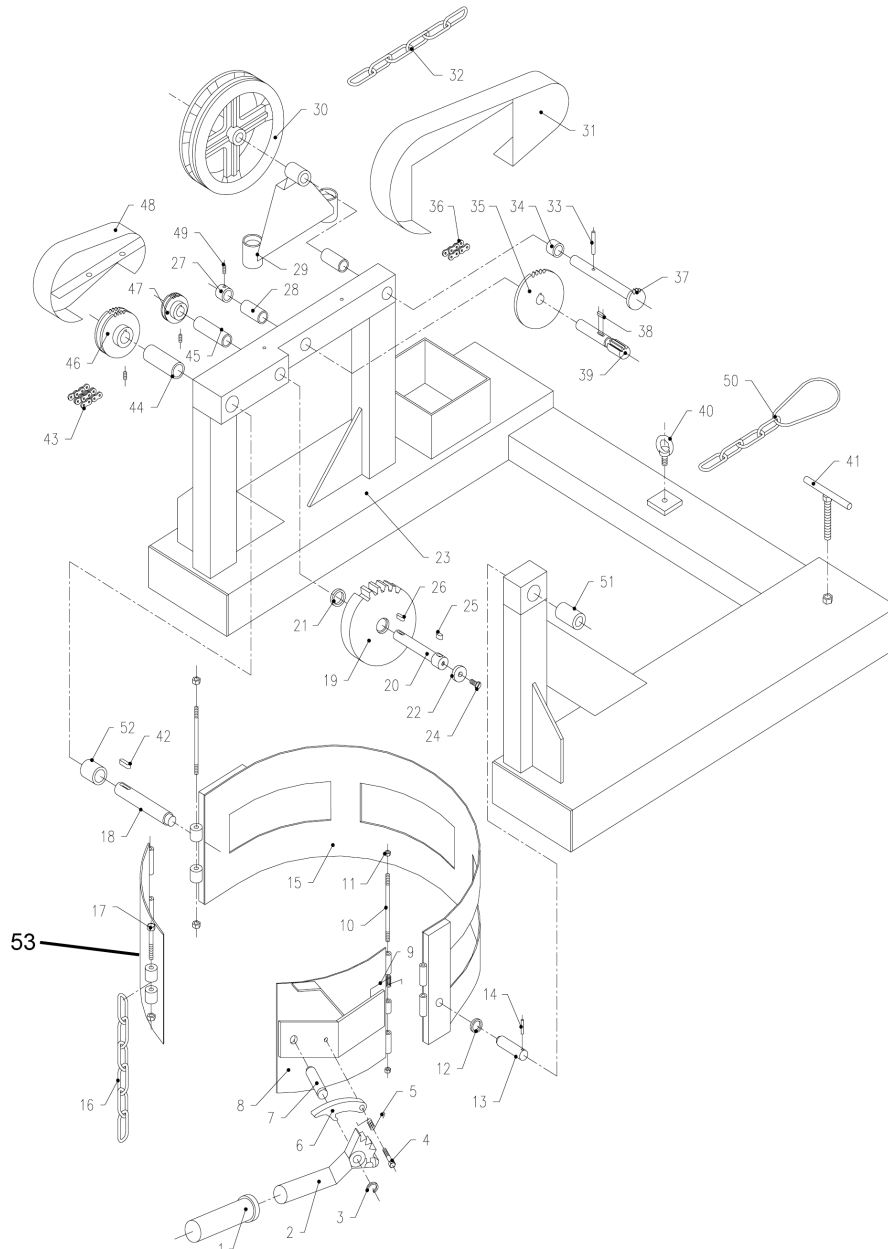

Item	Part no.	Description	Qty.	Item	Part no.	Description	Qty.	Item	Part no.	Description	Qty.
1	DCR-205-I-1	Bushing, rubber	1	19	DCR-205-I-19	Large gear	1	37	DCR-205-I-37	Shaft	1
2	DCR-205-I-2	Lever	1	20	DCR-205-I-20	Drive axle	4	38	DCR-205-I-38	Key	1
3	DCR-205-I-3	Ring, retaining	1	21	DCR-205-I-21	Ring	1	39	DCR-205-I-39	Gear axles	1
4	DCR-205-I-4	Bolt, hex head	1	22	DCR-205-I-22	Bushing	1	40	DCR-205-I-40	Screw	1
5	DCR-205-I-5	Spring	1	23	DCR-205-I-23	Pedestal assy.	1	41	DCR-205-I-41	Aligning bolt	2
6	DCR-205-I-6	Pawl	1	24	DCR-205-I-24	Screw	1	42	DCR-205-I-42	Key	1
7	DCR-205-I-7	Pin	1	25	DCR-205-I-25	Key	1	43	DCR-205-I-43	Chain double roller	1
8	DCR-205-I-8	Plate, ratchet	1	26	DCR-205-I-26	Key	1	44	DCR-205-I-44	Bushing	1
9	DCR-205-I-9	Spring	1	27	DCR-205-I-27	Alignment ring	1	45	DCR-205-I-45	Bushing	1
10	DCR-205-I-10	Double-ended bolt	1	28	DCR-205-I-28	Bushing	2	46	DCR-205-I-46	Double big chain wheel	1
11	DCR-205-I-11	Nut	2	29	DCR-205-I-29	Chain rack	1	47	DCR-205-I-47	Double small chain wheel	1
12	DCR-205-I-12	Ring	1	30	DCR-205-I-30	Chain wheel	1	48	DCR-205-I-48	Chain cover	1
13	DCR-205-I-13	Pin	1	31	DCR-205-I-31	Chain cover	1	49	DCR-205-I-49	Screw	3
14	DCR-205-I-14	Spring pin	1	32	DCR-205-I-32	Galvanized chain	1	50	DCR-205-I-50	Carriage chain or strap	1
15	DCR-205-I-15	Hoop	1	33	DCR-205-I-33	Spring pin	1	51	DCR-205-I-51	Bushing	1
16	DCR-205-I-16	Binder, chain	1	34	DCR-205-I-34	Pin	1	52	DCR-205-I-52	Ring	1
17	DCR-205-I-17	Hex bolt	1	35	DCR-205-I-35	Big chain wheel	1	53	DCR-205-I-53	Door	1

18	DCR-205-I-18	Pin	1	36	DCR-205-I-36	Roller chain	1			
----	--------------	-----	---	----	--------------	--------------	---	--	--	--

FIG. 3: DCR-205-12-DC EXPLODED VIEW AND BILL OF MATERIALS (09-006-112)

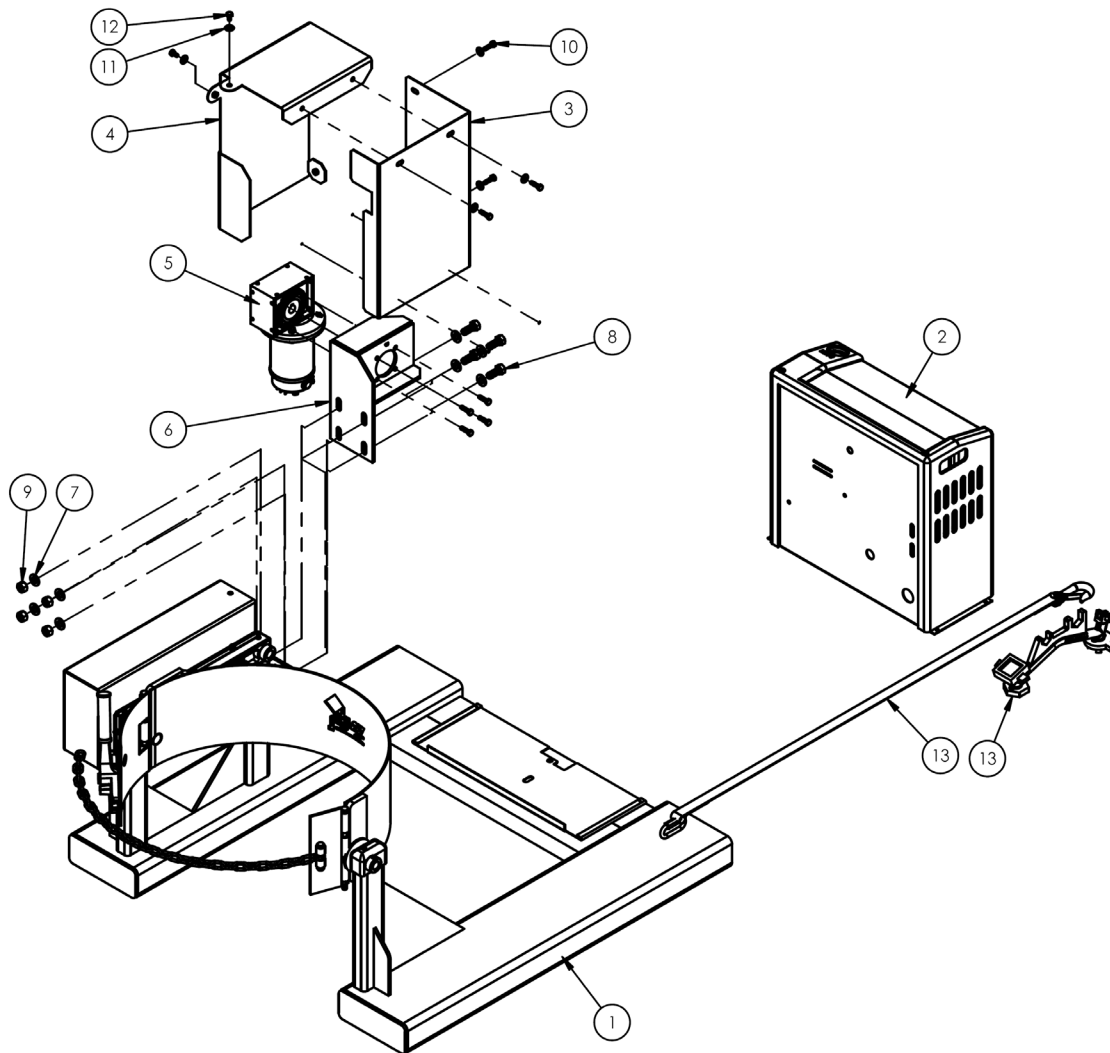

Item	Part No.	Description	Qty.	Item	Part No.	Description	Qty.
1	09-514-164	WELDMENT, FRAME W/SADDLE	1	8	11207	HHCS #2 Z Plated, GRADE A, Ø1/2 - 13 x 1 1/4 LG	4
2	99-160-097	FINAL ASS'Y, MOD. POWER UNIT-DC (XXE)	1	9	36110	HEX NUT Z-PLATED, GRADE A, Ø 1/2 - 13	4
3	09-024-018	GUARD, MOTOR SHROUD, FORMED	1	10	11005	BOLT, GRADE A, Ø1/4-20 UNC x 1 LG, HHCS #2 Z-PLATED	8
4	09-524-003	WELDMENT, GUARD, MOTOR SHROUD	1	11	33004	FLAT WASHER, USS, ZINC PLATED, Ø1/4"	6
5	21-641-005	MOTOR, WITH GEARBOX, SHAFT & KEY STOCK	1	12	11001	HEX BOLT, GRADE A, ZINC PLATED, 1/4"-20 X 1 1/2"	2
6	09-516-080	BRACKET, WELDMENT, MOTOR MOUNT	1	13	09-154-023	CARRIAGE STRAP AND BUNG WRENCH KIT	1
7	33011	FLAT WASHER, USS, PLAIN FINISH, Ø1/2"	8				

FIG. 4: DCR-205-15 EXPLODED VIEW AND BILL OF MATERIALS

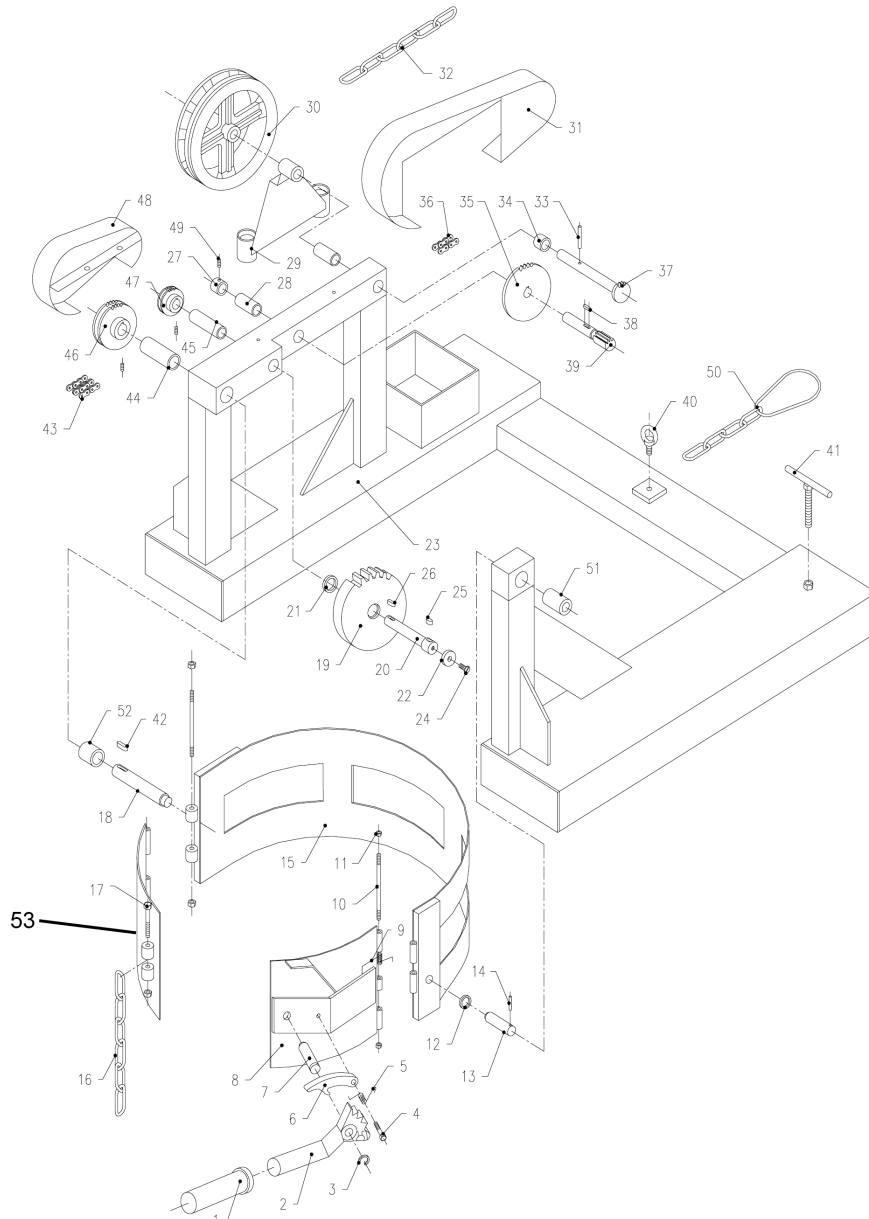

Item	Part no.	Description	Qty.	Item	Part no.	Description	Qty.	Item	Part no.	Description	Qty.
1	DCR-205-I-1	Bushing, rubber	1	19	DCR-205-I-19	Large gear	1	37	DCR-205-I-37	Shaft	1
2	DCR-205-I-2	Lever	1	20	DCR-205-I-20	Drive axle	4	38	DCR-205-I-38	Key	1
3	DCR-205-I-3	Ring, retaining	1	21	DCR-205-I-21	Ring	1	39	DCR-205-I-39	Gear axles	1
4	DCR-205-I-4	Bolt, hex head	1	22	DCR-205-I-22	Bushing	1	40	DCR-205-I-40	Screw	1
5	DCR-205-I-5	Spring	1	23	DCR-205-I-23	Pedestal assy.	1	41	DCR-205-I-41	Aligning bolt	2
6	DCR-205-I-6	Pawl	1	24	DCR-205-I-24	Screw	1	42	DCR-205-I-42	Key	1
7	DCR-205-I-7	Pin	1	25	DCR-205-I-25	Key	1	43	DCR-205-I-43	Chain double roller	1
8	DCR-205-I-8	Plate, ratchet	1	26	DCR-205-I-26	Key	1	44	DCR-205-I-44	Bushing	1
9	DCR-205-I-9	Spring	1	27	DCR-205-I-27	Alignment ring	1	45	DCR-205-I-45	Bushing	1
10	DCR-205-I-10	Double-ended bolt	1	28	DCR-205-I-28	Bushing	2	46	DCR-205-I-46	Double big chain wheel	1
11	DCR-205-I-11	Nut	2	29	DCR-205-I-29	Chain rack	1	47	DCR-205-I-47	Double small chain wheel	1
12	DCR-205-I-12	Ring	1	30	DCR-205-I-30	Chain wheel	1	48	DCR-205-I-48	Chain cover	1
13	DCR-205-I-13	Pin	1	31	DCR-205-I-31	Chain cover	1	49	DCR-205-I-49	Screw	3
14	DCR-205-I-14	Spring pin	1	32	DCR-205-I-32	Galvanized chain	1	50	DCR-205-I-50	Carriage chain or strap	1
15	DCR-205-I-15	Hoop	1	33	DCR-205-I-33	Spring pin	1	51	DCR-205-I-51	Bushing	1
16	DCR-205-I-16	Binder, chain	1	34	DCR-205-I-34	Pin	1	52	DCR-205-I-52	Ring	1
17	DCR-205-I-17	Hex bolt	1	35	DCR-205-I-35	Big chain wheel	1	53	DCR-205-I-53	Door	1
18	DCR-205-I-18	Pin	1	36	DCR-205-I-36	Roller chain	1				

FIG. 5: DCR-205-20 EXPLODED VIEW AND BILL OF MATERIALS (09-006-109)

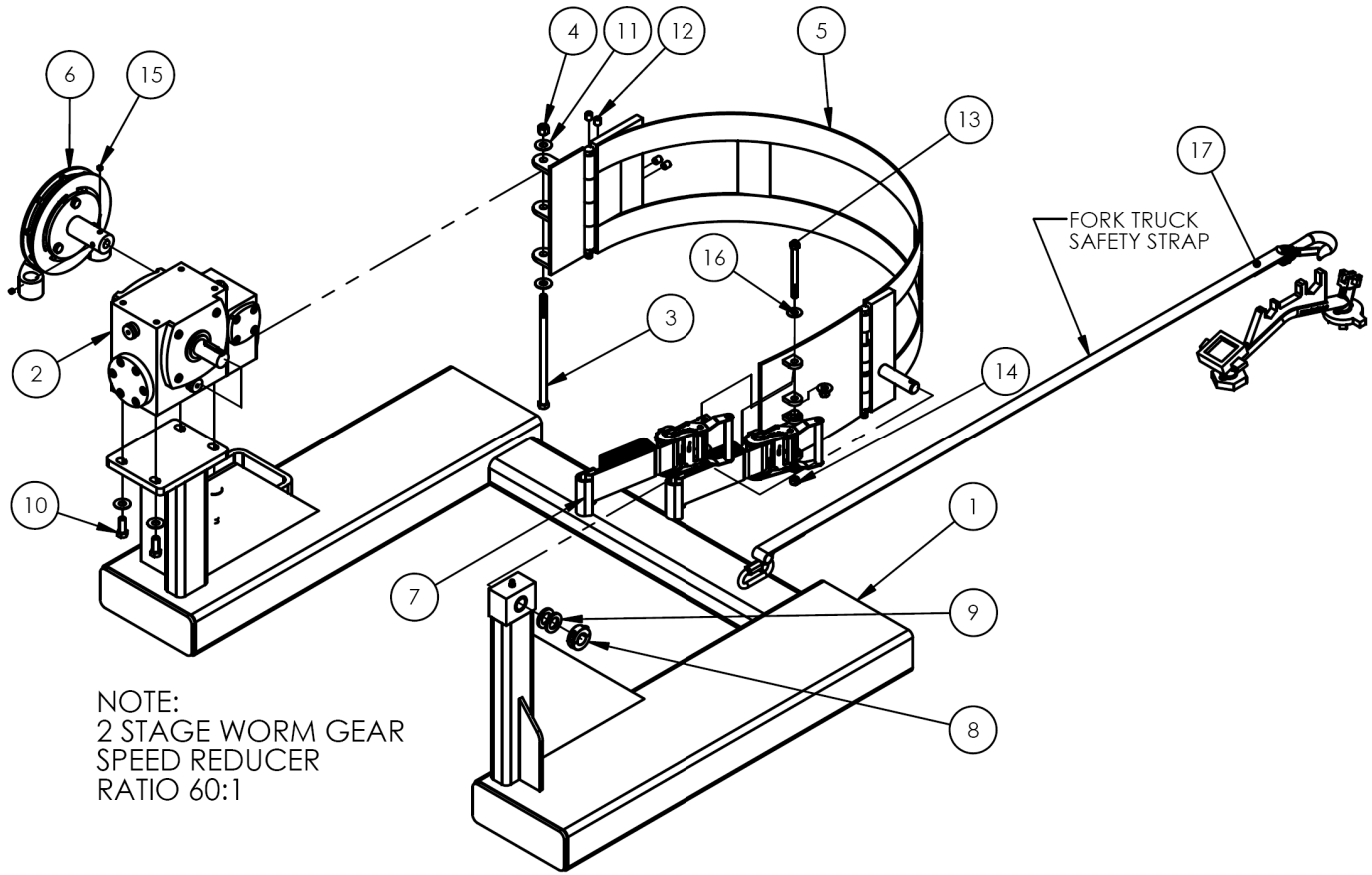

Item	Part No.	Description	Qty.	Item	Part No.	Description	Qty.
1	09-514-115	WELDMENT, FRAME	1	10	11105	HEX BOLT, GRADE A, ZINC PLATED, 3/8"-16 X 1"	4
2	09-141-001	REDUCER, GEAR	1	11	33008	FLAT WASHER, LOW CARBON, USS, ZINC PLATED, 3/8"	6
3	11129	HEX BOLT, GRADE A, ZINC FINISH, 3/8"- 16 X 8"	1	12	25539	SSS CP UTILITY GRADE, 3/8 - 16 UNC x 1/2 LG.	4
4	37024	NYLON INSERT LOCK NUT, GRADE 2, ZINC FINISH, 3/8"-16	1	13	13068	HHCS #5 Z PLATED, 5/16" - 18 x 3 3/4"	2
5	09-514-170	WELDMENT, DRUM CRADLE	1	14	36104	HEX NUT, GRADE A, ZINC PLATED, 5/16-18	2
6	09-542-007	SUB-ASSEMBLY, CHAIN WHEEL	1	15	25326	SOCKET SET SCREW, BLACK OXIDE, 1/4-20 X 1/4"	2
7	16-145-018	2" x 36" STRAP WITH RATCHET	2	16	33006	FLAT WASHER, ZINC PLATED, USS, Ø5/16"	4
8	34308	SPLIT SHAFT COLLAR, LOW CARBON STEEL, BLACK OXIDE FINISH, Ø3/4"	1	17	09-154-023	STRAP AND BUNG WRENCH KIT	1
9	33426	MACHINED BUSHING, LOW CARBON STEEL, PLAIN FINISH, Ø3/4"	2				

USING THE CARRIER: MANUAL MODELS [DCR-205-8; DCR-205-15; DCR-205-20]

NOTE: Only use this product to lift, transport, or dump 55 gallon drums.

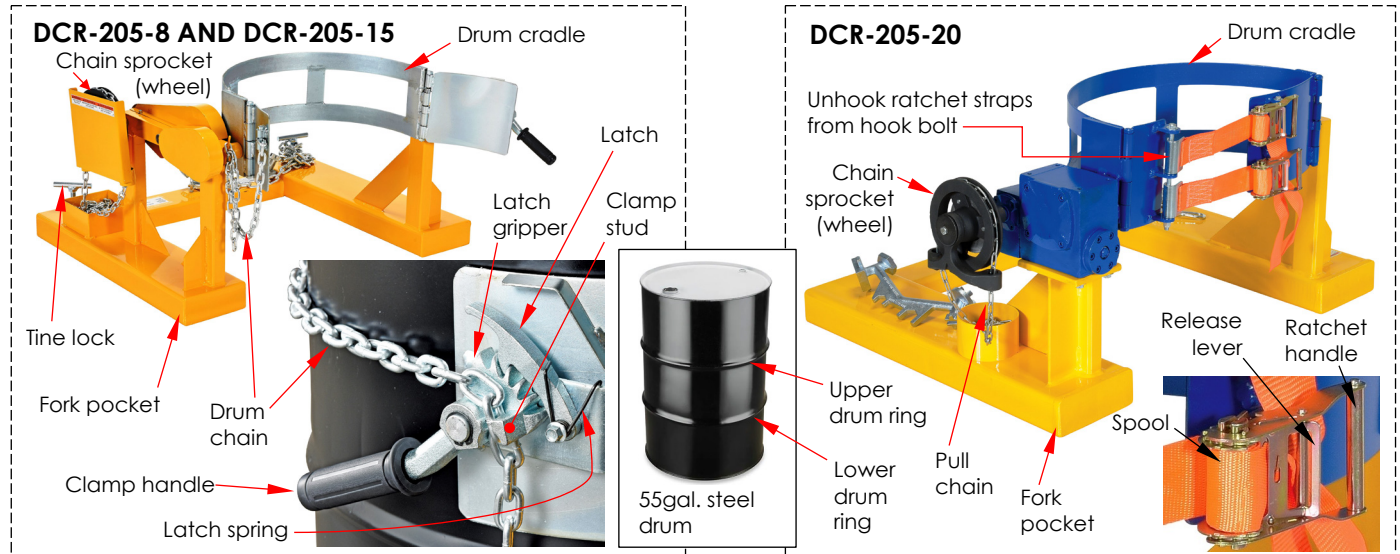

Step 1: Adjust the separation between fork truck tines to align with the fork pockets of the drum carrier. Tines should be at least 25¹/₂in. apart (inside edge to inside edge). Drive forward and insert the tines into the fork pockets. Drive forward until the tips of the tines contact the ends of the fork pockets.

DCR-205-8 and DCR-205-15: Tighten the tine locks against the tines. Turn the tine locks clockwise to tighten them.

Step 2: To prevent the carrier from sliding off the forks, attach the carriage strap/chain to the carriage of your lift truck *without slack*.

Step 3: Open the drum cradle.

DCR-205-8 and DCR-205-15: Lift the latch so that the latch tooth unseats from the latch gripper. Push the clamp handle down to unclamp the drum chain. Remove the chain from the clamp. Open the 2 hinged segments of the cradle.

DCR-205-20: Unhook the ratchet straps from the hook bolt. If the straps are too tight to unhook from the bolt, pull the release lever toward the handle (away from the spool) and pull on the strap until there is adequate slack to unhook the straps from the hook bolt. Open the hinged parts of the drum cradle. Drive toward the drum with tines just a few inches above the floor.

Step 4: Secure drum in the cradle. The cradle should contact the drum between the upper and lower drum rings. The top edge of the drum cradle should be just below the upper drum ring.

DCR-205-8 and DCR-205-15: Feed the chain into the chain clamp, i.e. between the clamp stud and the end of the clamp handle. Lift the clamp handle and solidly pinch a chain link between the end of the handle and the stud. The chain should be taut (no slack) against the side of the drum.

DCR-205-20: Hook the ratchet straps to the hook bolts. Move the ratchet handles back-and-forth to tighten the straps against the side of the drum.

Step 5: Remove the chain from the storage compartment. Place the end of the chain in the forklift cabin where it is easily accessible to the lift operator. Make sure that the drum is upright.

Step 6: Raise the forks a few inches from the ground and transport the drum to the dumping location. Hold the pull chain. Make sure that the chain is not tangled. Pull the lower segment of the chain towards you to rotate the drum forward. Pull the upper segment of the chain to rotate the drum backwards. Maintain control of the speed at which the drum rotates by grasping one arm of the chain and while pulling the other arm towards you. For example, rotate the drum forward and dump its contents by holding the upper segment of chain while pulling the lower segment towards you. When the drum is empty, rotate it back to the upright position. Hold the lower chain segment while pulling the upper segment.

Step 7: Move the drum to its offloading location with the drum elevated only as high as necessary. Lower the forks to set the drum on the ground. Disengage the drum by opening the clamp. Lift the latch so that the latch tooth unseats from the latch gripper. Rotate the clamp handle counterclockwise to unclamp the drum chain. Remove the chain from the clamp. Open the drum cradle and offload the drum.

Step 8: Store the drum carrier in a dry, indoor location.

USING THE CARRIER: POWERED ROTATORS (DCR-205-8-DC & DCR-205-12-DC)

Step 1: Adjust the separation between fork truck tines to align with the fork pockets of the drum carrier. Tines should be at least 25¹/₂in. apart (inside edge to inside edge). Drive forward to insert the tines into the fork pockets. Drive forward until the ends of the tines contact the ends of the fork pockets.

Step 2: To prevent the carrier from sliding off the forks, attach the carriage strap to the carriage of your lift truck *without slack*.

Step 3: Open the drum cradle.

Lift the latch so that the latch tooth unseats from the latch gripper. Rotate the clamp handle counterclockwise to unclamp the drum chain. Remove the chain from the clamp. Open the 2 hinged sections of the cradle.

Step 4: Drive toward the drum with carrier just a few inches above the floor. Engage the drum with the cradle. The cradle should contact the drum between the upper and lower drum rings. The top edge of the drum cradle should be just below the upper drum ring.

Step 5: Feed the drum chain between the end of the clamp handle and the clamp stud. Rotate the clamp handle clockwise until the chain is tightly pinched between the handle and the stud. The drum chain should be taut against the side of the drum (no slack).

Step 6: Turn the modular power unit on by turning the power switch to the ON position. Make sure that the red emergency stop button is pulled up. Place the handheld controller in the forklift cabin where it is easily accessible to the forklift operator. NOTE: Refer to the [MPU-DC GEN2 owner's manual](#) for more information about the modular power unit.

Step 7: Raise the forks a few inches from the ground. Make sure that the drum is upright. Transport the drum to the dumping location. Hold the handheld controller with the cord pointing toward you. Press the upper button on the handheld controller to rotate the top of the drum forward (away from the forklift). When the drum is empty, rotate it back to the upright position by pressing the lower button on the handheld controller.

Step 8: Move the drum to its offloading location with the drum elevated only as high as necessary. Lower the forks to set the drum on the ground. Disengage the drum by opening the clamp. Lift the latch so that the latch tooth unseats from the latch gripper. Rotate the clamp handle counterclockwise to unclamp the drum chain. Remove the chain from the clamp. Open the 2 hinged sections of the cradle. Offload the drum.

Step 9: Store the drum carrier in a dry, indoor location. Make sure that the power switch is turned OFF and the red E-stop button is pushed down.

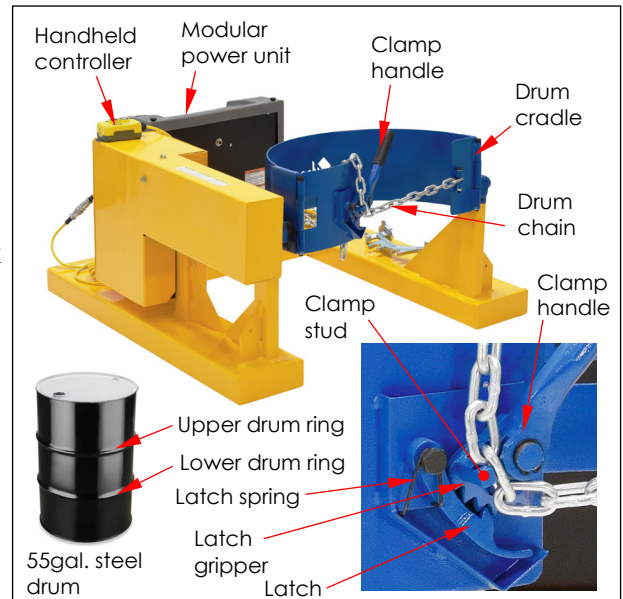

RECORD OF SATISFACTORY CONDITION (THE RECORD")

Before putting the drum carrier into service, record its condition. Thoroughly photograph the unit from multiple angles. Take close-range photographs of the drum cradle, the drum chain, the drum clamping mechanisms (handle, stud, latch, and latch gripper), all labels, pivot points, the safety strap/chain and snap hook, and fork/tine locks (if applicable). Use the carrier to lift a drum. Describe how the drum cradle and clamping mechanisms engage the drum. Describe all sounds produced by the lifter under load. Use the pull chain or handheld controller to rotate the drum. Describe the motion of the cradle as it rotates. Collect the photographs and writings in a file. Mark the file appropriately to identify it. This file is a record of the drum carrier in satisfactory condition. Compare the results of all inspections to this record to determine whether the unit is in satisfactory condition. Do not use the carrier unless it is in satisfactory condition. Purely cosmetic changes, like damaged paint or powdercoat are not changes from satisfactory condition. However, touchup paint should be applied to all affected areas as soon as the finish is damaged to prevent rust formation and metal erosion.

INSPECTIONS & MAINTENANCE

NOTICE

Proper use, maintenance, and storage are essential for this product to function properly.

- Inspect the unit as instructed and at least as frequently as recommended.
- Use this front end attachment as recommended in the current revision of ANSI/ITSDF B56.1 and all instructions in this manual.
- Store the unit in a dry location.

Inspection procedures are included in the most current revision of ANSI/ITSDF B56.1. As stated in [the NATIONAL STANDARDS](#) section on p. 3, Vestil recommends that you acquire a copy of the most recent revision of this standard. Apply all use and maintenance/care instructions in the standard. Vestil also recommends that you contact your local occupational health and safety authority to determine if any state or local laws, regulations, codes, ordinances, etc. apply inspection requirements where the carrier is used.

Inspections and all necessary repairs should be performed by qualified persons. Compare the results of each inspection to the [RECORD OF SATISFACTORY CONDITION](#). Do not use the crane unless every part is in satisfactory condition. Purely cosmetic changes, like damaged paint/powdercoat, are not changes from satisfactory condition. However, touchup paint must be applied as soon as damage occurs to prevent rust from forming. Rust could cause the affected part to become unsound, which could make the carrier unsafe to use.

DON'T GUESS! If you have any questions about the condition of your product, contact the [TECHNICAL SERVICE](#) department. The phone number is provided on the cover page of this manual. *Never make temporary repairs of damaged or missing parts.* Only use manufacturer-approved replacement parts to restore the crane to satisfactory condition.

INSPECTIONS

A. Before each use inspect the following components:

1. [Carriage strap/chain and snap hook](#): Confirm that the latch of the snap hook automatically closes. Examine the strap for cuts, tears, and areas of significant wear. Examine the snap hook (at the free end of the strap). It must not be bent or cracked or twisted.
2. [Labels](#): all labels must be easily readable and be located where indicated in the [LABELING DIAGRAM](#) on p. 12. If a label is unreadable or missing, contact the [TECHNICAL SERVICE AND REPLACEMENT PARTS DEPARTMENT](#) to order a replacement.

B. Periodic Inspections: At least once every 2 weeks inspect the carrier to confirm satisfactory condition. Do not return it to service unless it is in satisfactory condition.

1. [Fasteners \(hardware\) and hand chain](#):
 - Bolts, nuts, washers, and snap hooks: Tighten loose fasteners.
 - Hand chain (rotates the drum saddle): Inspect the chain links for breaks, cracks, elongations, severe wear, rusting and corrosion, and other forms of damage.
2. [Fork pockets](#): Confirm that each pocket is structurally sound. In particular, examine the underside of the each pocket for rust and corrosion.
3. [Welds](#): Make sure that all welds are intact. Check welds & the metal surrounding welds for damage.
4. [Drum cradle and clamp mechanism](#): Confirm that the cradle rotates properly. Apply the ratchet straps (DCR-205-20) or apply the clamp to the drum chain. The straps (DCR-205-20), when tightened, should not be able to disengage the hook bolts. The drum chain must not be able to pull free of the clamp without lifting the latch tooth free of the latch gripper.
5. [Drive train, chain sprocket, & pivot points](#): Rotate the drum saddle to confirm normal operation of the drive train and chain wheel. Lubricate pivot points and drive gears.
6. [Saddle hinges](#): Confirm that hinges operate normally. Lubricate the hinges. Lubrication might have to be applied more frequently under heavy usage conditions.
7. [Frame](#): The structure should be clean, square and rigid, and free of rust and corrosion. Clean the frame. Examine it for severe wear, rust, and other forms of damage.

MAINTENANCE

Step 1: Tag the unit "Out of Service."

Step 2: Remove any dirt or other matter from all surfaces.

Step 3: Conduct a “Periodic” inspection. If deformity, corrosion, rusting, or excessive wear of structural members is found, permanently remove the unit from service.

Step 4: Perform all necessary adjustments, replacements and/or repairs but DO NOT modify the carrier. DO NOT use the unit if adjustments and/or repairs are incomplete!

An “adjustment” is a simple correction that restores the unit to satisfactory condition, such as tightening loose fasteners, or removing dirt or other debris from the surface. “Repair” refers to removing worn parts and installing manufacturer-approved replacement parts.

A “modification” is a change that alters the drum carrier from satisfactory condition, like bending the structural members or removing a part or several parts. **NEVER** modify the unit without the express, written approval of Vestil. Modifications might make the device unsafe to use and *automatically* void the **LIMITED WARRANTY**.

Step 5: Make a dated record of all repairs, adjustments and/or replacements.

LABELING DIAGRAM

Label content and location are subject to change. Your product might not be labeled exactly as shown. Compare this diagram to your **RECORD OF SATISFACTORY CONDITION**. Replace all labels that are damaged, missing, or not easily readable (e.g. faded). Order replacement labels by contacting the **TECHNICAL SERVICE AND REPLACEMENT PARTS DEPARTMENT** online at http://www.vestilmfg.com/parts_info.htm. Alternatively, you may request replacement parts and/or service by calling (260) 665-7586 and asking the operator to connect you to the **PARTS DEPARTMENT**.

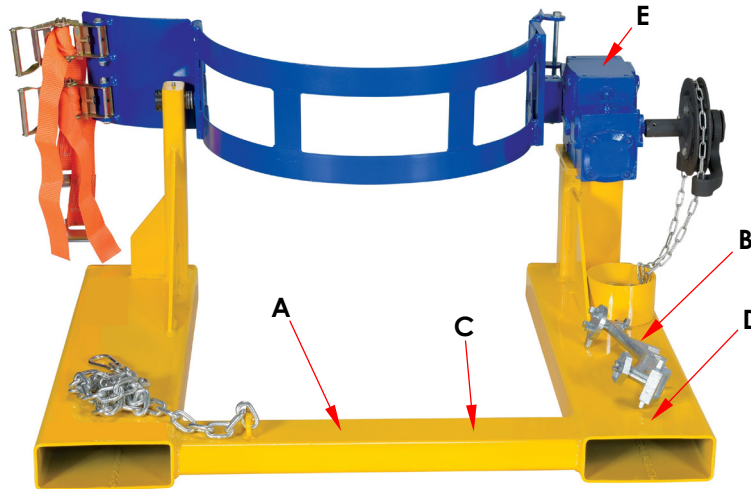

NOTE: Labeling diagram for modular power unit of DC-powered units provided in MPU-DC GEN2 owner manual.

A: Label 218: Fasten safety chain to carriage (on frame crossbar close to safety chain)

⚠ WARNING	⚠ ADVERTENCIAS
Improper use might result in death or serious personal injury. Attach device to fork carriage with safety chain/strap. <ul style="list-style-type: none"> • Drive lift truck forward until forks contact ends of fork pockets. • Chain/straps must not be able to disconnect (slide free) from carriage. • Safety chain/strap must be taut. Connect chain/strap to carriage via shortest line. 	El uso impropio puede resultar en muerte o heridas personales. Atar aparato al mástil del montacargas con cadenas/correas. <ul style="list-style-type: none"> • Maneje el montacargas para adelante hasta que las cuñas hagan contacto con la orilla del bolsillo de las cuñas. • La cadenas y correas no deben de deslizarse (soltarse) del mástil del montacargas. • La cadena/correa de seguridad debe de estar apretado. Asegure la cadena/correa al mástil via la ruta mas corta.

B: Label 232: Transport barrel in vertical position (on fork pocket near chain cup)

⚠ CAUTION	⚠ ATENCIÓN	⚠ ATTENTION
DRUM MUST BE IN VERTICAL POSITION WHEN MOVING	EL TAMBOR DEBE DE ESTAR EN LA POSICIÓN VERTICAL CUANDO EN MOVIMIENTO	LE BIDON DOIT ÊTRE EN POSITION VERTICALE LORS D'UN DÉPLACEMENT

C: Label 1153: Model, serial no. capacity (apply to frame crossbar)

MODEL/MODELO/MODÈLE _____	_____ lbs.
STATIC CAPACITY (evenly distributed) _____	_____ kgs.
LA CAPACIDAD CONSTANTE (distribuida uniformemente) _____	_____ kgs.
CAPACITÉ STATIQUE (distribuée régulièrement) _____	_____ kgs.
SERIAL/SERIE/SÉRIE _____	_____

E: Label 220: Keep clear when in use (on drivetrain guard)

⚠ WARNING	⚠ ADVERTENCIA	⚠ AVERTISSEMENT
KEEP CLEAR WHEN IN USE	MANTENGASE ALEJADO CUANDO SE ESTA OPERANDO	SE TENIR À DISTANCE LORS DU FONCTIONNEMENT

D: Label 1049: OSHA requirements (On fork pocket near chain cup)

⚠ WARNING
Improper use of this fork attachment might result in death or serious injury. <ul style="list-style-type: none"> • Using this front end attachment affects lift truck center of gravity. • Before using this fork attachment, US Federal regulation 29 CFR 1910.178 requires you to contact the manufacturer of your lift truck and request: <ol style="list-style-type: none"> 1. Written approval [29 CFR 1910.178(a)(4)] 2. Markings for (fork) lift truck that: <ul style="list-style-type: none"> - Identify the attachment; - Give approximate weight of truck and attachment at maximum elevation with laterally-centered load. [29 CFR 1910.178(a)(5)]. • DO NOT use UNTIL lift truck is marked with corrected capacity tags. • CAPACITY OF TRUCK & ATTACHMENT COMBINATION MIGHT BE LESS THAN CAPACITY OF ATTACHMENT. CONSULT TRUCK CAPACITY TAG/LABEL.

LIMITED WARRANTY

Vestil Manufacturing Corporation ("Vestil") warrants this product to be free of defects in material and workmanship during the warranty period. Our warranty obligation is to provide a replacement for a defective, original part covered by the warranty after we receive a proper request from the Warrantee (you) for warranty service.

Who may request service?

Only a warrantee may request service. You are a warrantee if you purchased the product from Vestil or from an authorized distributor AND Vestil has been fully paid.

Definition of "original part"?

An original part is a part used to make the product as shipped to the Warrantee.

What is a "proper request"?

A request for warranty service is proper if Vestil receives: 1) a photocopy of the Customer Invoice that displays the shipping date; AND 2) a written request for warranty service including your name and phone number. Send requests by one of the following methods:

<u>US Mail</u>	<u>Fax</u>	<u>Email</u>
Vestil Manufacturing Corporation 2999 North Wayne Street, PO Box 507 Angola, IN 46703	(260) 665-1339 <u>Phone</u> (260) 665-7586	info@vestil.com Enter "Warranty service request" in the subject field.

In the written request, list the parts believed to be defective and include the address where replacements should be delivered. After Vestil receives your request for warranty service, an authorized representative will contact you to determine whether your claim is covered by the warranty. Before providing warranty service, Vestil will require you to send the entire product, or just the defective part (or parts), to its facility in Angola, IN.

What is covered under the warranty?

The warranty covers defects in the following original, dynamic parts: motors, hydraulic pumps, motor controllers, and cylinders. It also covers defects in original parts that wear under normal usage conditions ("wearing parts"), such as bearings, hoses, wheels, seals, brushes, and batteries.

How long is the warranty period?

The warranty period for original dynamic components is 90 days. For wearing parts, the warranty period is 90 days. Both warranty periods begin on the date Vestil ships the product to the Warrantee. If the product was purchased from an authorized distributor, the periods begin when the distributor ships the product. Vestil may, at its sole discretion, extend a warranty period for products shipped from authorized distributors by up to 30 days to account for shipping time.

If a defective part is covered by the warranty, what will Vestil do to correct the problem?

Vestil will provide an appropriate replacement for any covered part. An authorized representative of Vestil will contact you to discuss your claim.

What is not covered by the warranty?

The Warrantee (you) is responsible for paying labor costs and freight costs to return the product to Vestil for warranty service.

Events that automatically void this Limited Warranty.

- Misuse;
- Negligent assembly, installation, operation or repair;
- Installation/use in corrosive environments;
- Inadequate or improper maintenance;
- Damage sustained during shipping;
- Collisions or other accidents that damage the product;
- Unauthorized modifications: Do not modify the product IN ANY WAY without first receiving written authorization from Vestil.

Do any other warranties apply to the product?

Vestil Manufacturing Corp. makes no other express warranties. All implied warranties are disclaimed to the extent allowed by law. Any implied warranty not disclaimed is limited in scope to the terms of this Limited Warranty. Vestil makes no warranty or representation that this product complies with any state or local design, performance, or safety code or standard. Noncompliance with any such code or standard is not a defect in material or workmanship.

